

# KPT-SPD101FHEV

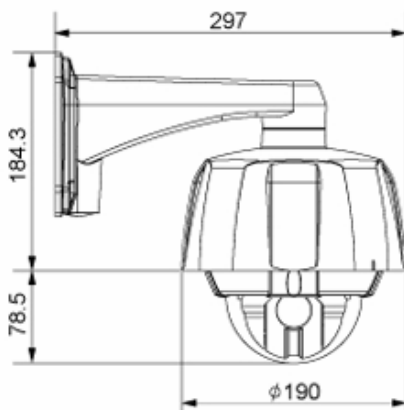

## Dimension



## Introduction

The Vandal Resistant KPT-SPD101FHEV is an Outdoor Mini SPEED DOME PTZ CAMERA.

This unit can monitor the target area efficiently with the PTZ control in all weather conditions.

## Special Features

- ⊙ Programmable AE(D/N, White Balance, Shutter Speed etc) per Preset
- ⊙ Optical 10x / Digital 10x Zoom
- ⊙ 520(Color)/570(B/W) TVL / 0.02 Lux (DSS/ICR) / Super Noise Reduction
- ⊙ Vandal Proof / Weather Resistant (IP66) / Built-in Fan & Heater
- ⊙ Standard Wall Mount kit / Optional Ceiling Poll Mount Available

Model	KPT-SPD101FHEV	
Signal Format	NTSC	
Camera	Device	1/4" Sony Super HAD CCD
	Total Pixels	410K Pixels [811(H) x 508(V)]
	Resolution	520 TV Lines(Color), 570 TV Lines(B/W)
	MIN. Illuminance	0.7 Lux (Color) / 0.02 Lux (B/W) @ 50 IRE
	Focus	Auto / Manual
	Iris	Auto
	BLC	On / Off
	Super Noise Reduction	Low / Mid / High / Off
	Zoom	10 X Optical Zoom and 10 X Digital Zoom
	White Balance	Auto / Manual / Indoor / Outdoor
	Focal Length	F1.8, f=3.8 ~ 38mm
	Day & Night	Auto / Day / Night ( ICR )
	Pan/Tilt	Range
Pan/Tilt Speed		Manual : 0.05° ~ 150/sec (Zoom Proportional)
		Preset : 360° /sec Swing : ~ 60° /sec (Zoom Proportional)
Preset		128 Presets / Programmable AE per Preset
Privacy Zone		4 Zones
Pattern		4 Patterns (MAX. 1 Minute Each)
Swing		8 Swings
Group	8 Groups ( MAX. 20 Entries)	
General	Sensor In/Out	4 Input
	Other	Auto Flip / Auto Parking
	Communication	RS-485
	Power	AC 24V / 0.4A
	Dimension	147.5(φ) x 141(H)mm
Operating Temp.	-30° C ~ 50° C / -22° F ~ 122° F	

Specifications may change without prior notice or liability



**KT&C USA, Inc.**

3240 Wilshire Blvd. Suite 501

Los Angeles, CA 90010

Tel 213-381-0061 Fax 213-381-0061

sales@ktncusa.com / www.ktncusa.com