

ACH13



2525 Park Central Blvd. Decatur, GA 30035
 1-800-554-1124 • www.videolarm.com



PRODUCT FEATURES

- Side hinge for easy access when servicing
- Accepts many lens and camera combinations
- Designed to meet IP65 standards
- Optional 24 VAC heater/blower, sunshield
- Optional WM800 light-duty steel bracket wall mount

ACH13 Outdoor Environmental

PRODUCT DESCRIPTION

The ACH13 is an outdoor, environmental housing that can accommodate camera/lens combinations up to 10.5" long and 3.6" wide. The body is an attractive white finish with black end caps. A heater/blower and sunshield are available.

OPTIONAL COMPONENTS AND ACCESSORIES:



ACH2
24Vac heater/
thermostat kit



ACHY
Sunshield for all ACH13 models



WM800
Medium-duty steel wall
mount bracket



CM800
Medium-duty steel corner
mount bracket, Max load
20 lbs



CA1200
Ceiling bracket,
Max load 20 lbs



WM2400
Medium-duty,
double-headed
wall bracket

MODELS:

ACH13 Environmental	IP Ready™	Heater/Blower		
		24Vac	12Vdc	Wall Mount
ACH13HBN	√	√		√
ACH13HB12N	√		√	√
ACH13		√		
ACH13WM	√	√		√
ACH13HBWM	√	√		√

ACH13 Environmental MODEL NUMBER SYSTEM:

A	C	H	1	3	H	B	W	M	2	N
Outdoor Environmental Housing			13"	Body	Heater / Blower Included		Wall Mount		24Vac Input	IP Ready Network
									12 12Vdc Input	

ACH13

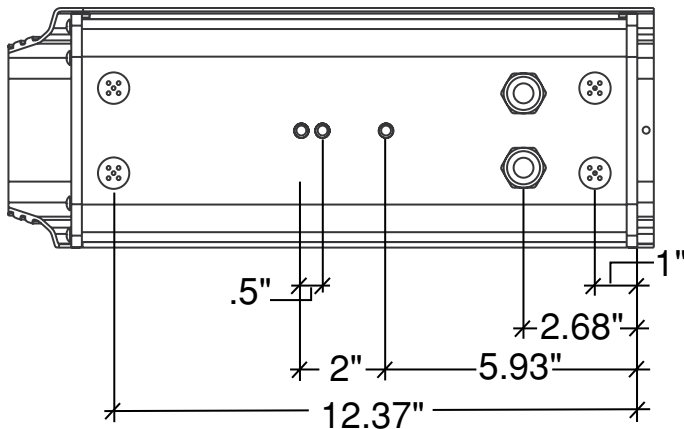
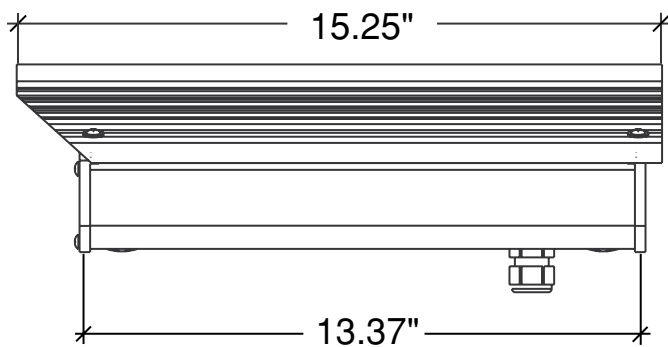
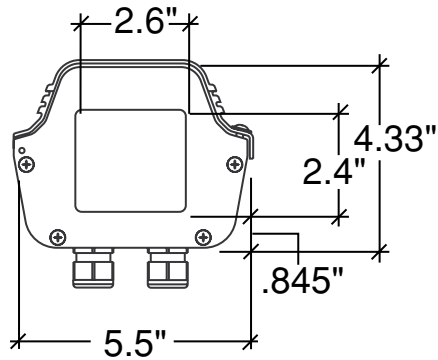

Mechanical Specifications

Size: (Product/shipping)	14.7" x 8.2" x 14.5" (h*w*d) 374 x 208 x 369mm
Weight: (Product/shipping)	11 lbs/ 5kg
Construction	Top: 3mm engineered plastic Dome: Polycarbonate
Mount Bracket:	Machined & cast aluminum

Environmental Specifications

Operating Temperature:	-20° F to 120° F -28° C to 48° C
Heater activates at	60° F (15° C)
Heater deactivates at	80° F (26° C)
Blower activates at	110° F (43° C)
Blower deactivates at	80° F (26° C)
Operating Humidity:	Up to 100%

Electrical Specifications

Power Source:	24vac model: 24vac 40watts (H/B 27 watts) 12vdc model: 12vdc, 50 watts (includes 20 watts for heater)
---------------	--

Shipping Specifications

Model	Shipping Weight	Box Dim.
ACH13	4 lbs	16 x 5 x 6
ACH13HBN	7 lbs	17 x 11 x 7

ACH13 Outdoor Environmental

CERTIFICATIONS AND RATINGS  

ARCHITECTURAL/ENGINEERING SPECIFICATIONS

The ACH13 environmental housing shall be constructed from two extruded aluminum (.08" wall thickness, white finish) halves and two injection-molded polycarbonate end caps. A clear polycarbonate viewing window shall be ultrasonically welded to the inside of the front end cap, creating a watertight seal. The rear end cap shall have molded standoffs on the inside surface for easy mounting of the optional blower. The top of the housing shall be hinged from the side to allow accessibility to the camera by one screw in each end cap. Camera adjustment or removal shall be provided via one screw located in the key hole slot on the aluminum camera sled. An optional 25 vA heater may be mounted to the inside of the bottom extrusion, directly behind the viewing window, for defogging and deicing. Four vent plugs (2 in front, 2 in rear) will create a positive air flow (front to rear) when the blower is in use. Two watertight strain relief plugs will be located at the rear of the housing for separate coax and power cable entry.