

29mm Cubic Analog B/W Camera

AEG2030

Series

AEG-U20

1/1.8" CCD 15fps

UXGA

AEG-X30

1/3" CCD 30fps

XGA

AEG-S20

1/2" CCD 15fps

SXGA

AEG-30

1/3" CCD 60fps/30fps

VGA



G-20 series 29mm cubic analog B/W camera

Its small size and light weight makes it a best match for use in embedded systems for image calibration and microscopic applications.

Features

- 29mm Cubic Size
- High Resolution
- High Frame Rate
- C Mount
- Analog VS OutputAa
- External Trigger Shutter
- Partial Scan Function



AEG-20/30

●Feature Overview

	VCC-G20U20	VCC-G20S20	VCC-G20X30	VCC-G20V30	
Resolution	UXGA	SXGA	XGA	VGA	
Sensor Type	1/1.8"CCD	1/2"CCD	1/3"CCD	1/3"CCD	
Power Consumption	2.4W	1.9W	2.0W	1.6W	
Input Voltage	DC+12V±10%				
Operating Conditions	Temperature 0°C~+40°C Humidity 20~80%				
Weight	Approx.44g				
Lens Mount	C Mount				
Optical Axis Accuracy	Pixel Center±0.1mm				
Video Output Signal	VS Output 1Vp-p (negative sync)				
Effective Number of Pixels	1628(H) × 1236(V)	1392(H) × 1040(V)	1034(H) × 779(V)	659(H) × 494(V)	
Horizontal Scan Frequency	18.75KHz	16KHz	23.622KHz	Standard 59.94KHz	Double Speed 119.88KHz
Pixel Clock	36MHz	28.636MHz	30MHz	24.545MHz	
Pixel Size	4.4 × 4.4(μm)	4.65 × 4.65(μm)	4.65 × 4.65(μm)	7.4 × 7.4(μm)	
Minimum Illumination	F1.4 2lx	F1.4 1lx	F1.4 2lx	F1.4 1lx (Double speed)	
Sensitivity	F8 400lx	F8 400lx	F5.6 400lx	F5.6 400lx (Double speed)	
Standard Color Temperature	3200° K				
Gain Switching	MANUAL 0dB~+12dB				
Electronic Shutter	OFF~1/10000 sec.				
Sync Method	Internal Sync. External Sync. HD/VD				
External Trigger	Fixed Shutter Exposure/Pulse Width Exposure				
Partial Scan	1/2、1/4、1/6 SCAN				
Other Functions	Binning Function			2:1 Interlace Mode	
Gamma Compensation	Default OFF (Option: 0.45)				
Control Interface	—				
Dimensions	29mm × 29mm × 29mm (excluding projection)				

●Dimensions

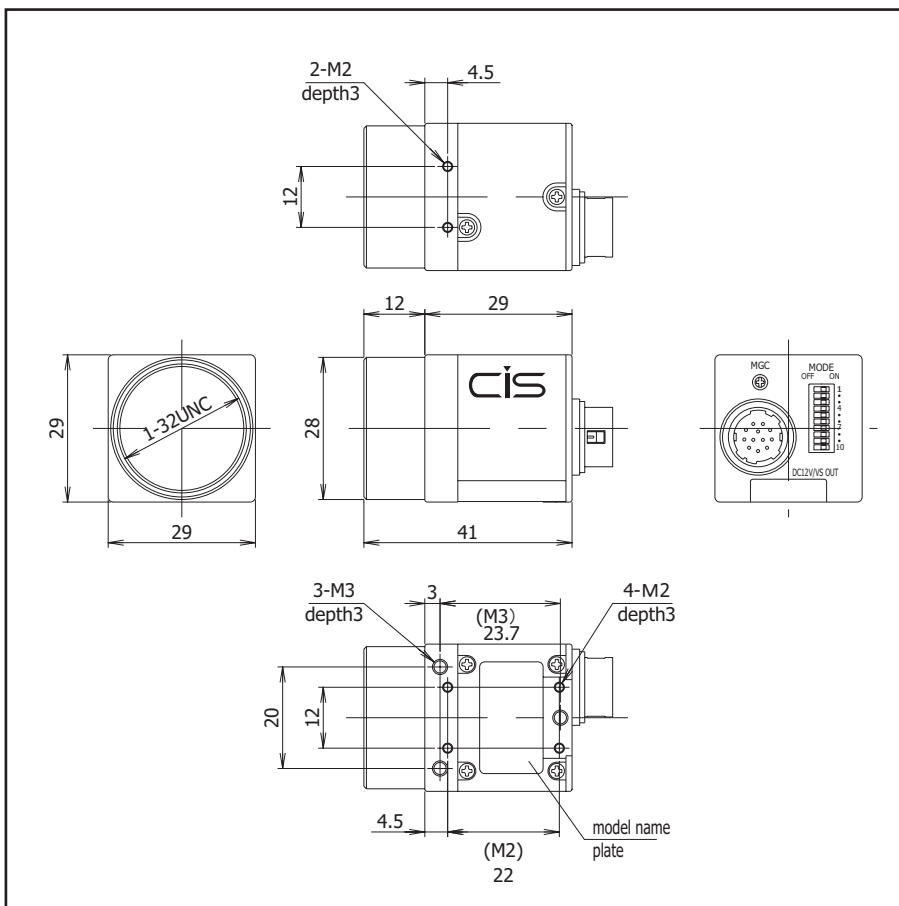

●Important Notice

Information contained herein is subject to change without prior notice.

●Manufacturer

CIS Corporation

539-5, Higashiasakawa-machi, Hachioji-shi,
Tokyo, 193-0834 Japan
TEL.+81-426-64-5535 FAX.+81-426-69-7471
<http://www.ciscorp.co.jp>

●Authorized Distributor

For further information on the product, please contact your authorized distributor.